

**QUANTIFICATION PROTOCOL  
FOR ACID GAS INJECTION**

Submitted to Alberta Environment

March 2008

## Table of Contents

1.0 Project and Methodology Scope and Description.....	2
1.1 Protocol Scope and Description.....	2
1.2 Glossary of New Terms .....	7
2.0 Quantification Development and Justification.....	8
2.1 Identification of Sources and Sinks (SS's) for the Project .....	8
2.2 Identification of Baseline.....	13
2.3 Identification of SS's for the Baseline .....	13
2.4 Selection of Relevant Project and Baseline SS's.....	18
2.5 Quantification of Reductions, Removals and Reversals of Relevant SS's.....	22
2.5.1 Quantification Approaches .....	22
2.5.2 Contingent Data Approaches .....	31
2.6 Management of Data Quality.....	31
2.6.1 Record Keeping.....	31
2.6.1 Quality Assurance/Quality Control (QA/QC).....	31

### List of Figures

FIGURE 1.1 Process Flow Diagram for Project Condition	3
FIGURE 1.2 Process Flow Diagram for Baseline Condition	4
FIGURE 2.1 Project Element Life Cycle Chart	8
FIGURE 2.2 Baseline Element Life Cycle Chart	13

### List of Tables

TABLE 2.1 Project SS's	9
TABLE 2.2 Baseline SS's	14
TABLE 2.3 Comparison of SS's	18
TABLE 2.4 Quantification Procedures	22
TABLE 2.5 Contingent Data Collection Procedures	30

## 1.0 Project and Methodology Scope and Description

This quantification protocol is written for the acid gas processing system operator or an acid gas project developer. Some familiarity with, or general understanding of, the operation of an acid gas processing facility is assumed.

The opportunity for generating carbon offsets with this protocol arises from the direct and indirect reductions of greenhouse gas (GHG) emissions resulting from the geological sequestration of acid gas streams containing greenhouse gasses as part of raw gas processing.

### 1.1 Protocol Scope and Description

Processing a raw gas stream for the purpose of producing a saleable natural gas product results in an acid gas waste stream by-product. The acid gas stream can contain significant amounts of both hydrogen sulphide (H<sub>2</sub>S), Carbon Dioxide (CO<sub>2</sub>) and other contaminants.

In the baseline condition for projects applying this protocol, the acid gas stream would be processed in;

- a Liquid Redox Process,
- in a Multi-Stage Claus unit, or
- directly incinerated.

where, in any case, the CO<sub>2</sub> would be released to the atmosphere during incineration of tail gas or acid gas (the latter in the direct incineration process). In the project condition capture and permanent containment of the entire acid gas stream reduces the quantity of CO<sub>2</sub> released to the atmosphere.

Further, the process of compression, transportation, and sequestration of acid gas reduces the quantity of GHG released to the atmosphere as it is less energy intensive than the baseline processes required for safe disposal of the acid gas stream. **Figure 1.1** offers a process flow diagram for a typical project. In some cases where a Multi-Stage Claus Unit is already in operation (in the actual vs. theoretical baseline) the operator may make the decision to maintain the process to produce elemental sulfur and steam from the Claus unit. This flexibility has been incorporated in the protocol.

Where the waste acid gas stream is injected into an active reservoir (where raw gas is actively being withdrawn) there is the opportunity for the CO<sub>2</sub> to be “recycled” – that is the same CO<sub>2</sub> molecule could be withdrawn with the raw gas – separated and re-injected over and over – resulting in an over estimation of the baseline condition and thus the resulting offset. With the objective of conservativeness where CO<sub>2</sub> is captured and injected into an active reservoir, the CO<sub>2</sub> will be considered recycled and no credit claimed.

Finally, the offsets resulting from Acid Gas Injection projects implemented in conformance with this protocol should be considered inherently permanent as a result of the project monitoring and robustness of the injection reservoir mandated by the regulator in the permitting phase.

### **Protocol Approach**

This protocol serves as a generic ‘recipe’ for project developers to follow in order to meet the measurement, monitoring and GHG quantification requirements for reductions from acid gas sequestration activities under controlled conditions.

The baseline condition represents the GHG emissions from incinerating the tail gas of a Liquid Redox Process or Multi-Stage Claus unit at an acid gas processing facility or from the direct incineration of an acid gas stream. The appropriate technology for the baseline condition is based on the concentration of H<sub>2</sub>S in the acid gas stream. Baseline emissions are therefore calculated from a theoretically appropriately sized Liquid Redox Process or Multi-Stage Claus Unit or directly from the concentration of the acid gas stream. If a Multi-Stage Claus Unit is specified, a significant thermal energy credit resulting from the exothermic reaction in the unit that needs to be considered. **FIGURE 1.2** offers a process flow diagram for a typical baseline configuration.

DRAFT

**FIGURE 1.1: Process Flow Diagram for Project Condition**

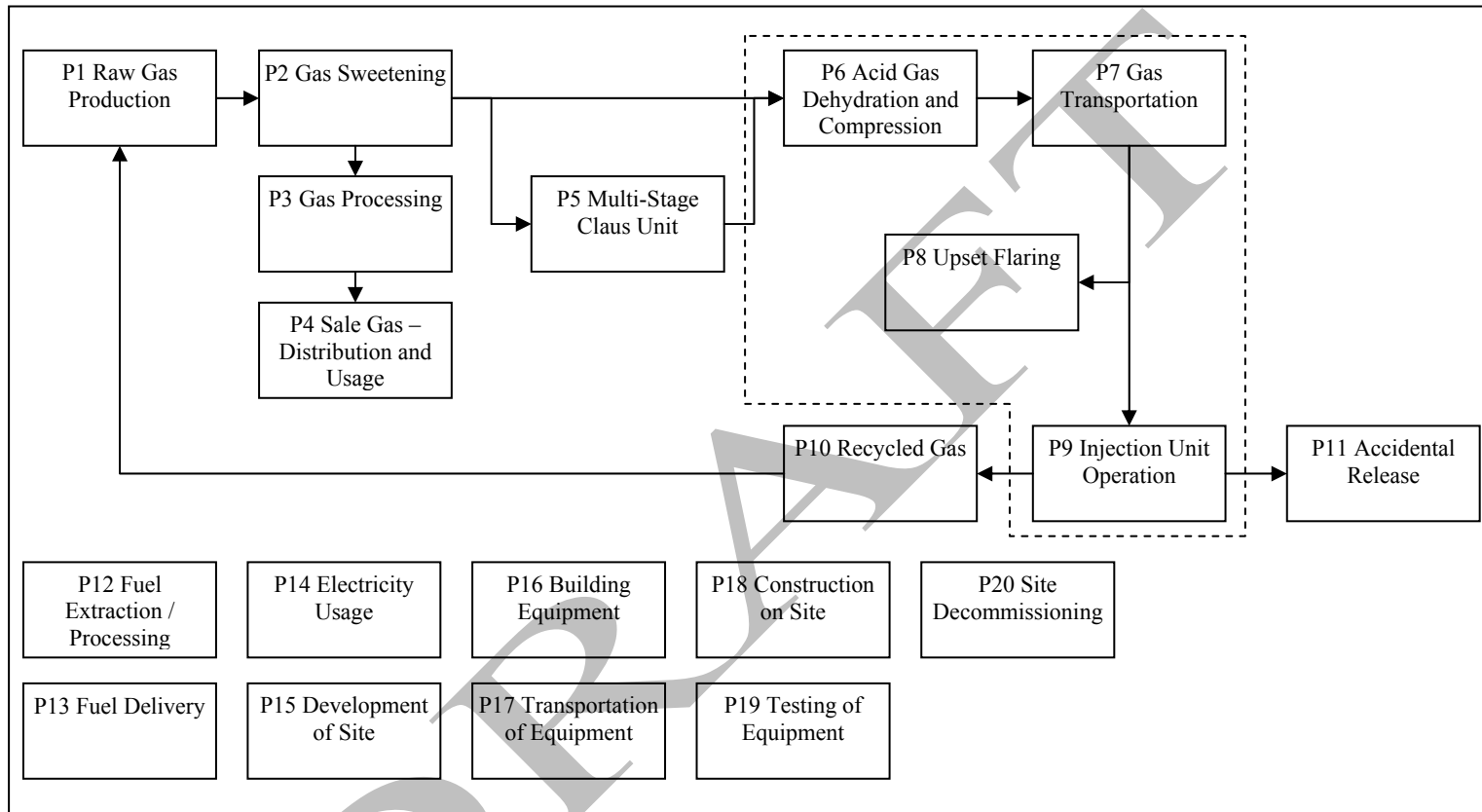

**FIGURE 1.2: Process Flow Diagram for Baseline Condition**

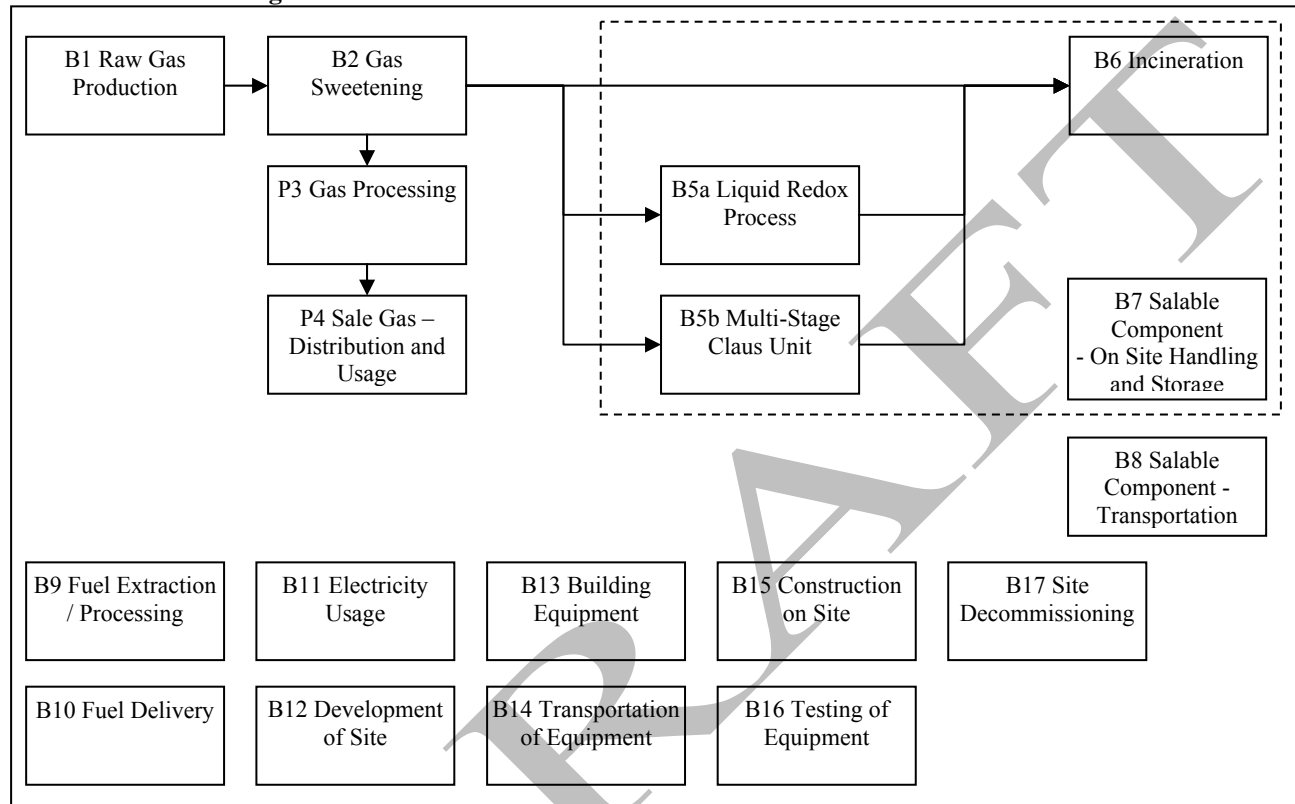

**Protocol Applicability:**

To demonstrate that a project meets the requirements under this protocol, the project developer must provide evidence that:

1. The sequestration project results in removal of emissions that would otherwise have been released to the atmosphere as indicated by an affirmation from the project developer and project schematics;
2. Where the entities/operations are separate and distinct, the emissions reduced are captured under the protocol and will be reported as being emitted at the source facility such that the emission reductions are not double counted;
3. The Acid Gas injection scheme has obtained approval from the Energy Resources Conservation Board (ERCB) and meets the requirements outlined under Directive 051: Injection and Disposal Wells – Well Classifications, Completions, Logging and Testing Requirements.
4. Metering of injected gas volumes takes place as close to the injection point as is reasonable to address the potential for fugitive emissions as demonstrated by a project schematics;
5. The quantification of reductions achieved by the project is based on actual measurement and monitoring (except where indicated in this protocol) as indicated by the proper application of this protocol; and
6. The project must meet the requirements for offset eligibility as specified in the applicable regulation and guidance documents for the Alberta Offset System.

**Protocol Flexibility:**

Flexibility in applying the quantification protocol is provided to project developers in the following ways:

1. Project developers may use alternative monitoring methodologies and/or equipment rather than the methodologies and/or equipment described in this protocol. The developer must justify that the chosen methodology and/or equipment provides equivalent or more conservative data than the specified equipment;
2. Site specific emission factors may be substituted for the generic emission factors indicated in this protocol document. The methodology for generation of these emission factors must be sufficiently robust as to ensure reasonable accuracy;
3. Where a significant volume of the raw gas is produced from the same reservoir as the acid gas injection well, an alternate methodology for

calculating the volume of recycled gas may be used. The proponent must justify that the chosen methodology provides verifiable data.

4. Projects may be developed where existing Claus units will remain in place. The baseline condition in this case should be redefined to exclude emissions resulting from the operation of the existing Claus unit.
5. The thermal energy credit produced by a Multi-Stage Claus unit may be calculated by relating the sulphur content of the acid gas input stream to the exothermic energy produced in the Claus process.
6. Where the thermal energy credit produced by a Claus unit is relatively small, the related emissions may be excluded. The proponent must justify the decision to exclude these emissions by demonstrating the relative quantity.

If applicable, the project developer must indicate and justify why flexibility provisions have been used.

## 1.2 Glossary of New Terms

Please refer to - <http://www.glossary.oilfield.slb.com/MainIndex.cfm?ID=1>

Acid Gas:	A gas that can form acidic solutions when mixed with water. The most common acid gases are hydrogen sulfide [H <sub>2</sub> S] and carbon dioxide [CO <sub>2</sub> ] gases. Both gases cause corrosion; hydrogen sulfide is extremely poisonous. Hydrogen sulfide and carbon dioxide gases are obtained after a sweetening process applied to a sour gas.
Acid Gas Injection:	Injection of acid gas into deep geological formations including, but not necessarily limited to, depleted oil and gas reservoirs and deep saline aquifers.
Aquifer:	A water-bearing portion of a petroleum reservoir with a water drive.
Reservoir:	A subsurface body of rock having sufficient porosity and permeability to store and transmit fluids. Sedimentary rocks are the most common reservoir rocks because they have more porosity than most igneous and metamorphic rocks and form under temperature conditions at which hydrocarbons can be preserved. A reservoir is a critical component of a complete petroleum system.

## 2.0 Quantification Development and Justification

The following sections outline the quantification development and justification.

### 2.1 Identification of Sources and Sinks (SS's) for the Project

Based on the process flow diagrams provided in **FIGURE 1.1**, the project SS's are organized into life cycle categories in **FIGURE 2.1**. Descriptions of each of the SS's and their classification as controlled, related or affected are provide in **TABLE 2.1**.

DRAFT

**FIGURE 2.1: Project Element Life Cycle Chart**

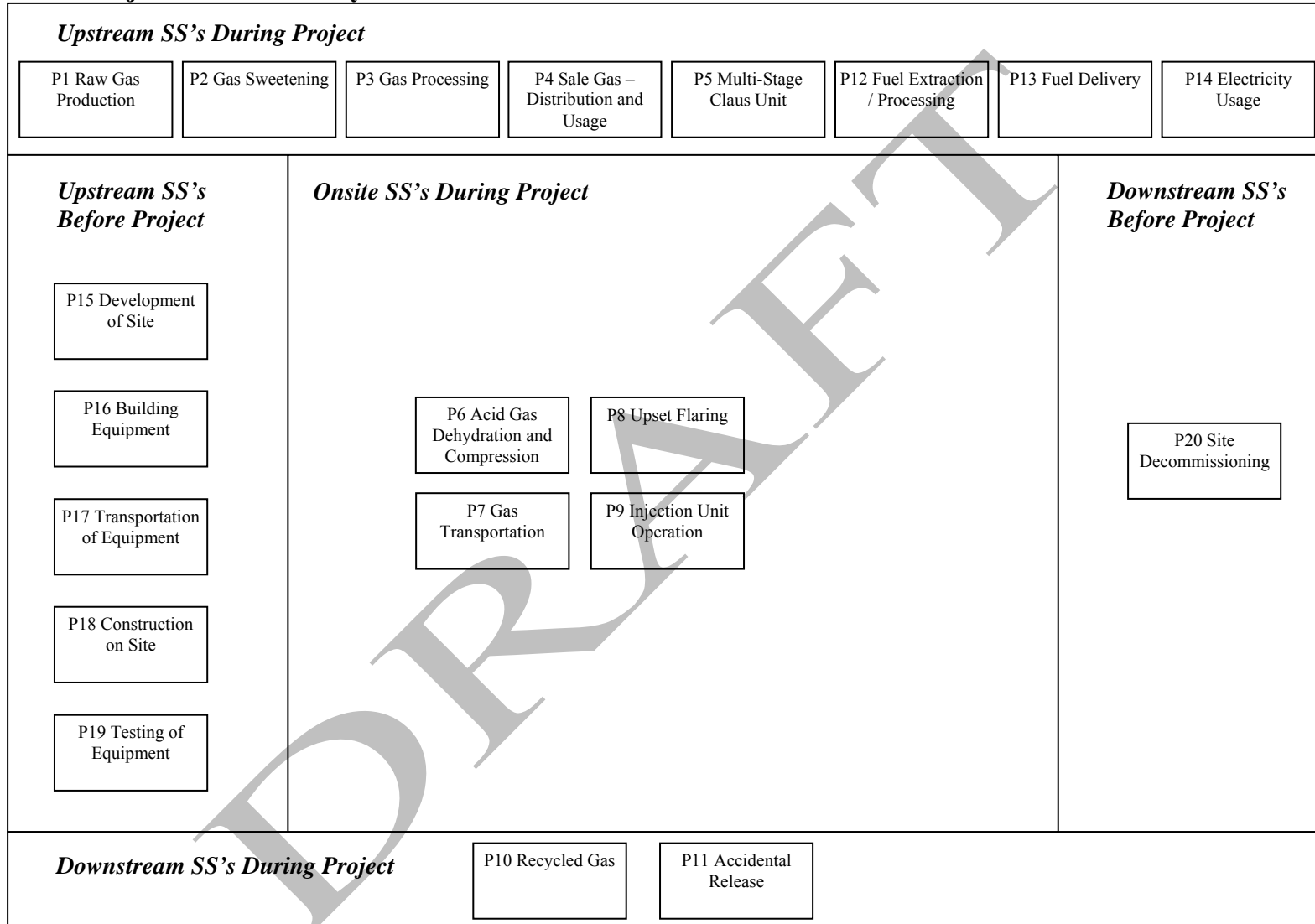

**Table 2.1: Project SS's (Sources and Sinks)**

1. SS	2. Description	3. Controlled, Related or Affected
<b>Upstream SS's during Project Operation</b>		
P1 Raw Gas Production	Raw gas is collected from a group of adjacent wells where the moisture content is reduced by removing water and natural gas condensate. Condensate is transported to oil refineries and wastewater is disposed. The raw gas is piped to processing plants. The quantity of GHG in the raw gas would need to be tracked. The types and quantities of fuels used in extraction equipment would need to be tracked.	Related
P2 Gas Sweetening	An amine treatment is applied to remove hydrogen sulfide and carbon dioxide. Volumes and types of energy inputs would need to be tracked.	Related
P3 Gas Processing	Further processing is required to remove water vapour and natural gas liquids (NGL) from the sales gas which is completed through different processes. The resulting sales gas contains small amounts of carbon dioxide. The types and quantities of energy required would need to be tracked. Carbon dioxide in sales gas would need to be tracked.	Related
P4 Sale Gas - Distribution and Usage	Natural Gas and other commercially viable NGL products may be input to a pipeline system or transported by rail or truck to customers at another point. The most likely use would be controlled combustion. The quantities of natural gas and NGL products would need to be tracked. Volumes and types of energy would need to be tracked.	Related
P12 Fuel Extraction / Processing	Each of the fuels used throughout the on-site component of the project will need to be sourced and processed. The total volumes of fuel for each of the on-site SS's are considered under this SS. Volumes and types of fuels are the important characteristics to be tracked.	Related
P13 Fuel Delivery	Each of the fuels used throughout the on-site component of the project will need to be transported to the site. This may include shipments by tanker or by pipeline contributing further greenhouse gas emissions. It is reasonable to exclude fuel sourced by taking equipment to an existing commercial fuelling station as the fuel used to take the equipment to the site is captured under other SS's.	Related
P11 Electricity Usage	Electricity may be produced off-site. Measurement of the quantity of electricity required by the facility would need to be tracked.	Related
<b>On-Site SS's during Project Operation</b>		
P5 Multi-Stage Claus Unit	A Multi-Stage Claus Unit may be used to reduce H <sub>2</sub> S content of the acid gas by removing elemental sulphur through a multi-stage process. The process is exothermic. Quantities and types for each of the energy inputs may need to be tracked. Net energy production from the process may need to be tracked.	Controlled

P6 Acid Gas Dehydration and Compression	The compressor system fuel may compose of diesel, natural gas or electricity and these additional GHG emissions are attributed to the project. Quantities and types for each of the energy inputs may need to be tracked.	Controlled
P7 Gas Transportation	Compressed acid gas may be shipped in a pipeline to an injection site. Fugitive emissions may occur from equipment used to transport injection gas. The quantity of fugitive emissions would need to be tracked.	Controlled
P8 Upset Flaring	Flaring of Acid Gas may be required during upset conditions or during maintenance to downstream elements. GHG emissions would result from the combustion of natural gas in the flaring process as well as the GHG content of the Acid Gas. Quantities of Acid Gas and natural gas as well as any pilot fuels would need to be tracked.	Controlled
P9 Injection Unit Operation	Additional compression and monitoring equipment may be required at the injections site. These systems may be fuelled by diesel or natural gas resulting in GHG emissions. Quantities and types for each of the energy inputs may need to be tracked.	Controlled
P11 Accidental Release	Geologically sequestered gas may escape from reservoir. Six potential escape pathways have been identified in the IPCC Special Report on Carbon Dioxide Capture and Storage.	Controlled
<b>Downstream SS's during Project Operation</b>		
P10 Recycled Gas	Injection gas may be re-circulated through production wells in the area. The re-circulated gas would be captured and fed back into the process. The quantity of re-circulated gas would need to be tracked.	Related
<b>Other</b>		
P15 Development of Site	Development of the site could include clearing, grading, building access roads as well as civil infrastructure such as access to electricity, gas, water supply and water treatment. Building and structures on the site including offices, storage facilities, storm water drainage, and structures to enclose, support and house equipment may need to be developed. Greenhouse gas emissions would be primarily attributed to the use of fossil fuels and electricity used to power equipment required to develop the site.	Related
P16 Building Equipment	Equipment may need to be built either on-site or off-site. This includes all of the components of the storage, handling, processing, combustion, air quality control, system control and safety systems. These may be sourced as pre-made standard equipment or custom built to specification. Greenhouse gas emissions would be primarily attributed to the use of fossil fuels and electricity used to power equipment for the extraction of the raw materials, processing, fabricating and assembly.	Related
P17 Transportation of Equipment	Equipment built off-site and the materials to build equipment on-site, will all need to be delivered to the site. Transportation may be completed by truck, barge and/or train. Greenhouse gas emissions would be primarily attributed to the use of fossil fuels to power the equipment delivering the equipment to the site.	Related
P18 Construction on Site	The process of construction at the site will require a variety of heavy equipment, smaller power tools, cranes and generators. The operation of this equipment will have associated greenhouse gas emission from the use of fossil fuels and electricity	Related

P19 Testing of Equipment	Equipment may need to be tested to ensure that it is operational. This may result in running the equipment using fossil fuels in order to ensure that the equipment runs properly. These activities will result in greenhouse gas emissions associated with the combustion of fossil fuels and the use of electricity.	Related
P20 Site Decommissioning	Once the facility is no longer operational, the site may need to be decommissioned. This may involve the disassembly of the equipment, demolition of on-site structures, disposal of some materials, environmental restoration, re-grading, planting or seeding, and transportation of materials off-site. Greenhouse gas emissions would be primarily attributed to the use of fossil fuels and electricity used to power equipment required to decommission the site.	Related

DRAFT

## 2.2 Identification of Baseline

The baseline condition for projects applying this protocol is defined as the volume of carbon dioxide that would be released to the atmosphere during incineration of the tail gas from a Liquid Redox Process or Multi-Stage Claus unit at an acid gas processing facility or from the direct incineration of an acid gas stream. Additionally, the emissions associated with fueling the Liquid Redox Process or Multi-Stage Claus unit and the incineration process would be included in the baseline emissions. The technology choice and theoretical design is dependant upon the concentration of hydrogen sulphide and carbon dioxide in the acid gas input stream. The baseline is thus project-specific.

The approach to quantifying the baseline will be calculation based, as there are suitable measurement based data available for the applicable baseline condition that can provide reasonable certainty. The baseline scenario for this protocol is dynamic as the volume of carbon dioxide would be expected to change materially relative to the makeup of the acid gas stream. The baseline condition may vary from project to project.

The baseline condition is defined, including the relevant SS's and process, as shown in **FIGURE 1.2**. More detail on each of these SS's is provided in Section 2.3 below.

## 2.3 Identification of SS's for the Baseline

Based on the process flow diagrams provided in **FIGURE 1.2**, the project SS's were organized into life cycle categories in **FIGURE 2.2**. Descriptions of each of the SS's and their classification as either 'controlled', 'related' or 'affected' is provided in **TABLE 2.2**.

**FIGURE 2.2: Baseline Element Life Cycle Chart**

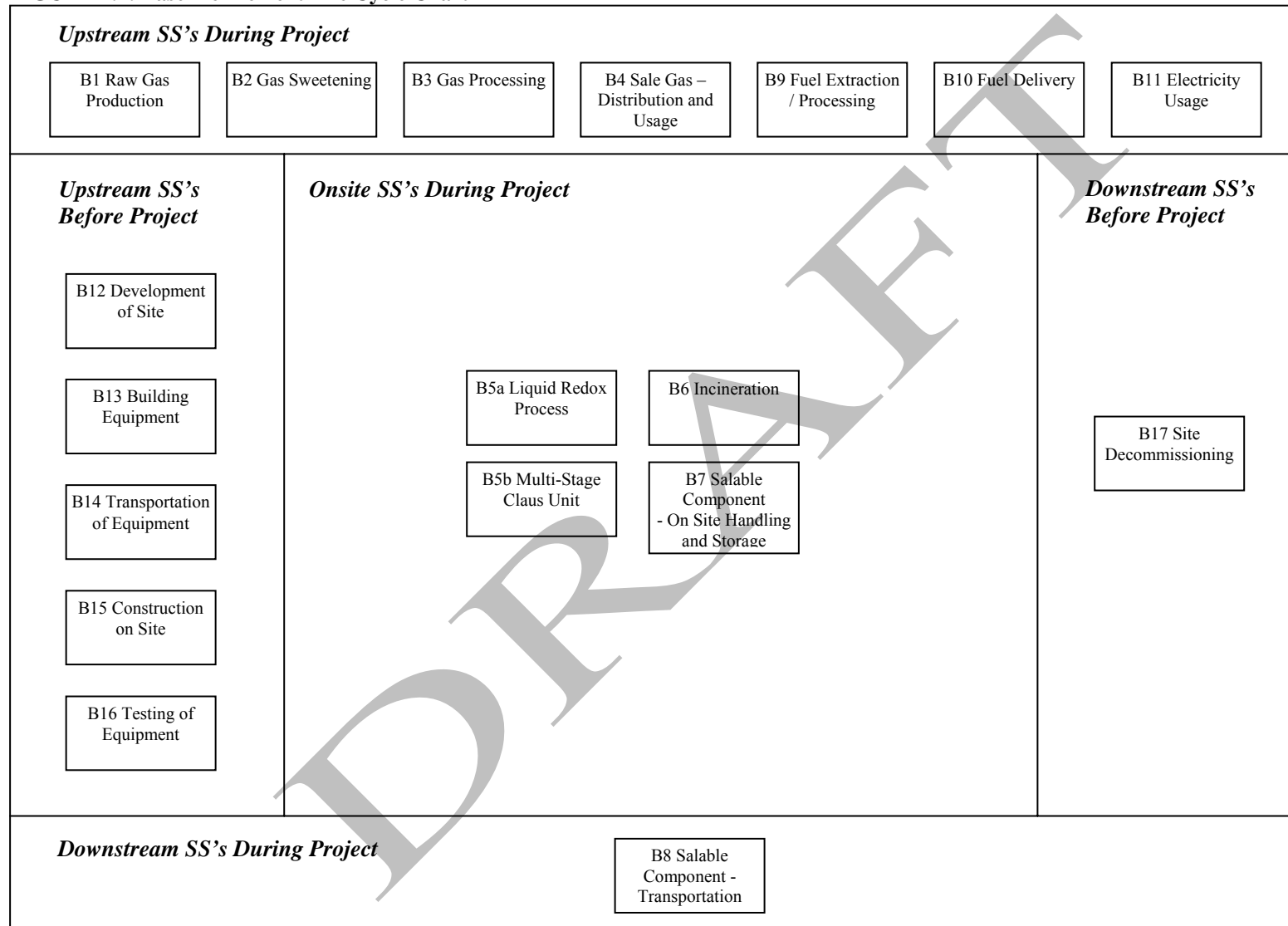

**Table 2.2: Baseline SS's**

1. SS	2. Description	3. Controlled, Related or Affected
<b>Upstream SS's during Baseline Operation</b>		
B1 Raw Gas Production	Raw gas is collected from a group of adjacent wells where the moisture content is reduced by removing water and natural gas condensate. Condensate is transported to oil refineries and wastewater is disposed of. The raw gas is piped to processing plants. The quantity of GHG in the raw gas would need to be tracked. The types and quantities of fuels used in extraction equipment would need to be tracked.	Related
B2 Gas Sweetening	An amine treatment is applied to remove hydrogen sulfide and carbon dioxide. Volumes and types of energy inputs would need to be tracked.	Related
B3 Gas Processing	Further processing is required to remove water vapour, mercury, nitrogen, and natural gas liquids from the sales gas which is completed through different processes. The resulting sales gas contains small amounts of carbon dioxide. The types and quantities of energy required would need to be tracked. Carbon dioxide in sales gas would need to be tracked.	Related
B4 Sale Gas – Distribution and Usage	Natural Gas and other commercially viable NGL products may be input to a pipeline system or transported by rail or truck to customers at another point. The most likely use would be controlled combustion. The quantities of natural gas and NGL products would need to be tracked. Volumes and types of energy would need to be tracked.	Related
B9 Fuel Extraction / Processing	Each of the fuels used throughout the on-site component of the project will need to be sourced and processed. The total volumes of fuel for each of the on-site SS's are considered under this SS. Volumes and types of fuels are the important characteristics to be tracked.	Related
B10 Fuel Delivery	Each of the fuels used throughout the on-site component of the project will need to be transported to the site. This may include shipments by tanker or by pipeline attributing additional greenhouse gas emissions.. It is reasonable to exclude fuel sourced by taking equipment to an existing commercial fuelling station as the fuel used to take the equipment to the site is captured under other SS's and there is no other delivery.	Related
B11 Electricity Usage	Electricity may be produced off-site. Measurement of the quantity of electricity required by the facility would need to be tracked.	Related
<b>Upstream SS's during Baseline Operation</b>		

B5a Liquid Redox Process	Elemental sulphur is recovered from hydrogen sulfide through a process that employs aqueous-based solutions containing metal ions. The process requires electricity as well as heat that may be provided by the combustion of fuels including natural gas or other fuels. Greenhouse gas emissions from the combustion of fuel or consumption of electricity would need to be tracked.	Controlled
B5b Multi-Stage Claus Unit	Elemental sulphur is recovered from hydrogen sulfide through multiple thermal and catalytic reactions. The reactions require heat that may be provided by the combustion of fuels including natural gas or other fuels. Pumps and other equipment require electricity. Greenhouse gas emissions from the combustion of fuel or consumption of electricity would need to be tracked.	Controlled
B6 Incineration	Residual Acid Gas not recovered during the upstream process needs to be incinerated. GHG emissions would result from the combustion of natural gas in the flaring process as well as the GHG content of the Acid Gas. Quantities of Acid Gas and natural gas as well as any pilot fuels would need to be tracked.	Controlled
B7 Saleable Component – On Site Handling and Storage	Liquid or solid sulphur produced through the Claus process will need to be handled on site and potentially stored before being transported to market. Equipment to handle sulphur would be fuelled by electricity, diesel, gasoline, propane or natural gas, resulting in GHG emissions. Quantities and types for each of the energy inputs may need to be tracked.	Controlled
<b>Downstream SS's during Baseline Operation</b>		
B8 Saleable Component - Transportation	Salable elemental sulphur may require further processing and transportation to end users by rail or truck resulting in greenhouse gas emissions. The quantity of emissions would need to be tracked.	Controlled
<b>Other</b>		
B12 Development of Site	Development of the site could include clearing, grading, building access roads as well as civil infrastructure such as access to electricity, gas, water supply and water treatment. Building and structures on the site including offices, storage facilities, storm water drainage, and structures to enclose, support and house equipment may need to be developed. Greenhouse gas emissions would be primarily attributed to the use of fossil fuels and electricity used to power equipment required to develop the site.	Related
B13 Building Equipment	Equipment may need to be built either on-site or off-site. This includes all of the components of the storage, handling, processing, combustion, air quality control, system control and safety systems. These may be sourced as pre-made standard equipment or custom built to specification. Greenhouse gas emissions would be primarily attributed to the use of fossil fuels and electricity used to power equipment for the extraction of the raw	Related

	materials, processing, fabricating and assembly.	
B14 Transportation of Equipment	Equipment built off-site and the materials to build equipment on-site, will all need to be delivered to the site. Transportation may be completed by truck, barge and/or train. Greenhouse gas emissions would be primarily attributed to the use of fossil fuels to power the equipment delivering the equipment to the site.	Related
B15 Construction on Site	The process of construction at the site will require a variety of heavy equipment, smaller power tools, cranes and generators. The operation of this equipment will have associated greenhouse gas emission from the use of fossil fuels and electricity.	Related
B16 Testing of Equipment	Equipment may need to be tested to ensure that it is operational. This may result in running the equipment using fossil fuels in order to ensure that the equipment runs properly. These activities will result in greenhouse gas emissions associated with the combustion of fossil fuels and the use of electricity.	Related
B17 Site Decommissioning	Once the facility is no longer operational, the site may need to be decommissioned. This may involve the disassembly of the equipment, demolition of on-site structures, disposal of some materials, environmental restoration, re-grading, planting or seeding, and transportation of materials off-site. Greenhouse gas emissions would be primarily attributed to the use of fossil fuels and electricity used to power equipment required to decommission the site.	Related

#### **2.4 Selection of Relevant Project and Baseline SS's**

Each of the SS's from the project and baseline condition were compared and evaluated as to their relevancy using the guidance provided in Annex VI of the "Guide to Quantification Methodologies and Protocols: Draft", dated March 2006 (Environment Canada). The justification for the inclusion, exclusion, or conditions upon which SS's may be excluded is provided in **TABLE 2.3** below.

DRAFT

**TABLE 2.3: Comparison of SS's**

1. SS	2. Baseline (C, R, A)	3. Project (C, R, A)	4. Include or Exclude from Quantification	5. Justification for Exclusion
<b>Upstream SS's</b>				
P1 Raw Gas Production	N/A	Related	Exclude	Excluded as raw gas production is not impacted by the implementation of project and as such baseline and project conditions will be functionally equivalent.
B1 Raw Gas Production	Related	N/A	Exclude	
P2 Gas Sweetening	N/A	Related	Exclude	Excluded as gas sweetening process is not impacted by the implementation of project and as such baseline and project conditions will be functionally equivalent.
B2 Gas Sweetening	Related	N/A	Exclude	
P3 Gas Processing	N/A	Related	Exclude	Excluded as gas processing is not impacted by the implementation of project and as such baseline and project conditions will be functionally equivalent.
B3 Gas Processing	Related	N/A	Exclude	
P4 Sale Gas – Distribution and Usage	N/A	Related	Exclude	Excluded as emissions from the distribution and usage of upstream products are not impacted by the implementation of project and as such baseline and project conditions will be functionally equivalent.
B4 Sale Gas – Distribution and Usage	Related	N/A	Exclude	
P12 Fuel Extraction / Processing	N/A	Related	<b>Include</b>	N/A
B9 Fuel Extraction / Processing	Related	N/A	<b>Include</b>	N/A
P13 Fuel Delivery	N/A	Related	Exclude	Excluded as emissions from fuel delivery are not impacted by the implementation of project and as such baseline and project conditions will be functionally equivalent.
B10 Fuel Delivery	Related	N/A	Exclude	
P14 Electricity Usage	N/A	Related	Exclude	Excluded as these SS's are not relevant to the project as the emissions from these practices are covered under proposed GHG regulations.
B11 Electricity Usage	Related	N/A	Exclude	
<b>Onsite SS's</b>				
P5 Multi-Stage Claus Unit	N/A	Controlled	Exclude	Excluded as emissions from the Multi-Stage Claus Unit are not impacted by the implementation of project and as such baseline and project conditions will be functionally equivalent.
P6 Acid Gas Dehydration and Compression	N/A	Controlled	<b>Include</b>	N/A

B5a Liquid Redox Process	Controlled	N/A	<b>Include</b>	N/A
B5b Gas Processing – Multi-Stage Claus Unit	Controlled	N/A	<b>Include</b>	N/A
P7 Gas Transportation	N/A	Controlled	Exclude	Excluded as monitoring of transportation pipeline is highly regulated under H <sub>2</sub> S regulation and probability of occurrence is extremely low.
B6 Incineration	Controlled	N/A	<b>Include</b>	N/A
P8 Upset Flaring	N/A	Controlled	<b>Include</b>	N/A
B7 Saleable Component – On Site Handling and Storage	Controlled	N/A	Exclude	Excluded as the emissions from on-site handling and storage of saleable component are not material and occur only under the baseline.
P9 Injection Unit Operation	Controlled	N/A	<b>Include</b>	N/A
P10 Recycled Gas	N/A	Related	<b>Include</b>	N/A
P11 Accidental Release	N/A	Controlled	Exclude	Excluded as monitoring of reservoir is highly regulated under H <sub>2</sub> S regulation and probability of occurrence is extremely low.
<b>Downstream SS's</b>				
B8 Saleable Component – Transportation	Related	N/A	Exclude	Excluded as the emissions from transportation of saleable component are not material and occur only under the baseline.
<b>Other SS's</b>				
P15 Development of Site	N/A	Related	Exclude	Emissions from site development are not material given the long project life and the minimal site development typically required.
B12 Development of Site	Related	N/A	Exclude	Emissions from site development are not material for the baseline condition given the minimal site development typically required.
P16 Building Equipment	N/A	Related	Exclude	Emissions from building equipment are not material given the long project life and the minimal equipment typically required.
B13 Building Equipment	Related	N/A	Exclude	Emissions from building equipment are not material for the baseline condition given the minimal equipment typically required.
P17 Transportation of Equipment	N/A	Related	Exclude	Emissions from transportation of equipment are not material given the long project life and the minimal transportation of equipment typically required.

B14 Transportation of Equipment	Related	N/A	Exclude	Emissions from transportation of equipment are not material for the baseline condition given the minimal transportation of equipment typically required.
P18 Construction on Site	N/A	Related	Exclude	Emissions from construction on site are not material given the long project life and the minimal construction on site typically required.
B15 Construction on Site	Related	N/A	Exclude	Emissions from construction on site are not material for the baseline condition given the minimal construction on site typically required.
P19 Testing of Equipment	N/A	Related	Exclude	Emissions from testing of equipment are not material given the long project life and the minimal testing of equipment typically required.
B16 Testing of Equipment	Related	N/A	Exclude	Emissions from testing of equipment are not material for the baseline condition given the minimal testing of equipment typically required.
P20 Site Decommissioning	N/A	Related	Exclude	Emissions from site decommissioning are not material given the long project life and the minimal site decommissioning typically required.
B17 Site Decommissioning	Related	N/A	Exclude	Emissions from site decommissioning are not material for the baseline condition given the minimal site decommissioning typically required.

## 2.5 Quantification of Reductions, Removals and Reversals of Relevant SS's

### 2.5.1 QUANTIFICATION APPROACHES

Quantification of the reductions, removals and reversals of relevant SS's for each of the greenhouse gases will be completed using the methodologies outlined in **TABLE 2.4**, below. A listing of relevant emission factors is provided in **APPENDIX A**. These calculation methodologies serve to complete the following three equations for calculating emission reductions from the comparison of baseline and project conditions.

$$\text{Emissions Reduction} = \text{Emissions}_{\text{Baseline}} - \text{Emissions}_{\text{Project}}$$

$$\text{Emissions}_{\text{Baseline}} = \text{Emissions}_{\text{Fuel Extraction / Processing}} + \text{Emissions}_{\text{Liquid Redox Process}} + \text{Emissions}_{\text{Multi-Stage Claus Unit}} + \text{Emissions}_{\text{Incineration}}$$

$$\text{Emissions}_{\text{Project}} = \text{Emissions}_{\text{Fuel Extraction / Processing}} + \text{Emissions}_{\text{Gas Compression}} + \text{Emissions}_{\text{Upset Flaring}} + \text{Emissions}_{\text{Injection Unit Operation}} + \text{Emissions}_{\text{Recycled Gas}}$$

Where:

Emissions Baseline = sum of the emissions under the baseline condition.

$\text{Emissions}_{\text{Fuel Extraction / Processing}}$  = emissions under SS B9 Fuel Extraction / Processing

$\text{Emissions}_{\text{Liquid Redox Process}}$  = emissions under SS B5a Liquid Redox Process

$\text{Emissions}_{\text{Multi-Stage Claus Unit}}$  = emissions under SS B5b Multi-Stage Claus Unit

$\text{Emissions}_{\text{Incineration}}$  = emissions under SS B6 Incineration

Emissions Project = sum of the emissions under the project condition.

$\text{Emissions}_{\text{Fuel Extraction / Processing}}$  = emissions under SS P12 Fuel Extraction / Processing

$\text{Emissions}_{\text{Gas Dehydration and Compression}}$  = emissions under SS P6 Acid Gas Dehydration and Compression

$\text{Emissions}_{\text{Upset Flaring}}$  = emissions under SS P8 Upset Flaring

$\text{Emissions}_{\text{Injection Unit Operation}}$  = emissions under SS P9 Injection Unit Operation

$\text{Emissions}_{\text{Recycled Gas}}$  = emissions under SS P10 Recycled Gas

**TABLE 2.4: Quantification Procedures**

1.0 Project/Baseline SS	2. Parameter / Variable	3. Unit	4. Measured / Estimated	5. Method	6. Frequency	7. Justify measurement or estimation and frequency
<b>Project SS's</b>						
P12 Fuel Extraction / Processing	Emissions <sub>Fuel Extraction / Processing</sub> = $\Sigma (\text{Vol. Fuel}_i * \text{EF Fuel}_i \text{CO}_2)$ ; $\Sigma (\text{Vol. Fuel}_i * \text{EF Fuel}_i \text{CH}_4)$ ; $\Sigma (\text{Vol. Fuel}_i * \text{EF Fuel}_i \text{N}_2\text{O})$ ;					
	Emissions <sub>Fuel Extraction / Processing</sub>	kg of CO <sub>2</sub> ; CH <sub>4</sub> ; N <sub>2</sub> O	N/A	N/A	N/A	Quantity being calculated in aggregate form as fuel use on site is likely aggregated for each of these SS's.
	Volume of Each Type of Fuel Combusted for P6 to P9 / Vol. Fuel <sub>i</sub>	L / m <sup>3</sup> / other	Measured	Direct metering or reconciliation of volume in storage (including volumes received).	Continuous metering or monthly reconciliation	Both methods are standard practice. Frequency of metering is highest level possible. Frequency of reconciliation provides for reasonable diligence.
	CO <sub>2</sub> Emissions Factor for Fuel Including Production and Processing / EF Fuel <sub>i</sub> CO <sub>2</sub>	kg CO <sub>2</sub> per L / m <sup>3</sup> / other	Estimate	From Environment Canada reference documents. (Appendix A)	Annual	Reference values adjusted annually as part of Environment Canada's emissions inventory.
	CH <sub>4</sub> Emissions Factor for Fuel Including Production and Processing / EF Fuel <sub>i</sub> CH <sub>4</sub>	kg CH <sub>4</sub> per L / m <sup>3</sup> / other	Estimate	From Environment Canada reference documents. (Appendix A)	Annual	Reference values adjusted annually as part of Environment Canada's emissions inventory.
	N <sub>2</sub> O Emissions Factor for Fuel Including Production and Processing / EF Fuel <sub>i</sub> N <sub>2</sub> O	kg N <sub>2</sub> O per L / m <sup>3</sup> / other	Estimate	From Environment Canada reference documents. (Appendix A)	Annual	Reference values adjusted annually as part of Environment Canada's emissions inventory.
P6 Acid Gas Dehydration and Compression	Emissions <sub>Gas Dehydration and Compression</sub> = $\Sigma (\text{Vol. Fuel}_i * \text{EF Fuel}_i \text{CO}_2)$ ; $\Sigma (\text{Vol. Fuel}_i * \text{EF Fuel}_i \text{CH}_4)$ ; $\Sigma (\text{Vol. Fuel}_i * \text{EF Fuel}_i \text{N}_2\text{O})$					
	Emissions <sub>Gas Dehydration and Compression</sub>	kg of CO <sub>2</sub> ; CH <sub>4</sub> ; N <sub>2</sub> O	N/A	N/A	N/A	Quantity being calculated in aggregate form as fuel use on site is likely aggregated for each of these SS's.

1.0 Project/Baseline SS	2. Parameter / Variable	3. Unit	4. Measured / Estimated	5. Method	6. Frequency	7. Justify measurement or estimation and frequency
	Volume of Each Type of Fuel Used / Vol. Fuel <sub>i</sub>	L / m <sup>3</sup> / other	Measured	Direct metering or reconciliation of volume in storage (including volumes received).	Continuous metering or monthly reconciliation	Both methods are standard practice. Frequency of metering is highest level possible. Frequency of reconciliation provides for reasonable diligence.
	CO <sub>2</sub> Emissions Factor for Each Type of Fuel / EF Fuel <sub>iCO2</sub>	kg CO <sub>2</sub> per L / m <sup>3</sup> / other	Estimate	From Environment Canada reference documents. (Appendix A)	Annual	Reference values adjusted annually as part of Environment Canada's emissions inventory.
	CH <sub>4</sub> Emissions Factor for Each Type of Fuel / EF Fuel <sub>iCH4</sub>	kg CH <sub>4</sub> per L / m <sup>3</sup> / other	Estimate	From Environment Canada reference documents. (Appendix A)	Annual	Reference values adjusted annually as part of Environment Canada's emissions inventory.
	N <sub>2</sub> O Emissions Factor for Each Type of Fuel / EF Fuel <sub>iN2O</sub>	kg N <sub>2</sub> O per L / m <sup>3</sup> / other	Estimate	From Environment Canada reference documents. (Appendix A)	Annual	Reference values adjusted annually as part of Environment Canada's emissions inventory.
P8 Upset Flaring	Emissions <sub>Upset Flaring</sub> = (Vol. AG Flared * % CO <sub>2</sub> * ρ <sub>CO2</sub> ); Σ (Vol. Fuel <sub>i</sub> * EF Fuel <sub>iCO2</sub> ); Σ (Vol. Fuel <sub>i</sub> * EF Fuel <sub>iCH4</sub> ); Σ (Vol. Fuel <sub>i</sub> * EF Fuel <sub>iN2O</sub> )					
	Emissions <sub>Upset Flaring</sub>	Kg of CO <sub>2</sub> ; CH <sub>4</sub> ; N <sub>2</sub> O	N/A	N/A	N/A	Quantity being calculated in aggregate form as fuel use on site is likely aggregated for each of these SS's.
	Volume of Acid Gas Flared / Vol. AG Flared	m <sup>3</sup>	Measured	Direct metering of volume of AG being flared	Continuous metering	Direct metering is standard practice. Frequency of metering is highest level possible.
	Carbon Dioxide Composition in AG / % CO <sub>2</sub>	%	Measured	Direct measurement	Daily sampling averaged monthly on a volumetric basis	Acid gas composition should remain relatively stable during steady-state operation. Frequency of sampling provides for reasonable diligence.
	Density of CO <sub>2</sub> / ρ <sub>CO2</sub>	kg / m <sup>3</sup>	Constant	1.98 kg/m <sup>3</sup> at STP	N/A	Accepted value

1.0 Project/Baseline SS	2. Parameter / Variable	3. Unit	4. Measured / Estimated	5. Method	6. Frequency	7. Justify measurement or estimation and frequency
	Volume of Each Type of Fuel used to Supplement Flare / Vol Fuel <sub>i</sub>	L / m <sup>3</sup> / other	Measured	Direct metering or reconciliation of volume in storage (including volumes received).	Continuous metering or monthly reconciliation.	Both methods are standard practice. Frequency of metering is highest level possible. Frequency of reconciliation provides for reasonable diligence.
	CO <sub>2</sub> Emissions Factor for Each Type of Fuel / EF Fuel <sub>i CO2</sub>	kg CO <sub>2</sub> per L / m <sup>3</sup> / other	Estimate	From Environment Canada reference documents. (Appendix A)	Annual	Reference values adjusted annually as part of Environment Canada's emissions inventory.
	CH <sub>4</sub> Emissions Factor for Each Type of Fuel / EF Fuel <sub>i CH4</sub>	kg CH <sub>4</sub> per L / m <sup>3</sup> / other	Estimate	From Environment Canada reference documents. (Appendix A)	Annual	Reference values adjusted annually as part of Environment Canada's emissions inventory.
	N <sub>2</sub> O Emissions Factor for Each Type of Fuel / EF Fuel <sub>i N2O</sub>	kg N <sub>2</sub> O per L / m <sup>3</sup> / other	Estimate	From Environment Canada reference documents. (Appendix A)	Annual	Reference values adjusted annually as part of Environment Canada's emissions inventory.
P9 Injection Unit Operation	Emissions <sub>Injection Unit Operation</sub> = $\sum (\text{Vol. Fuel}_i * \text{EF Fuel}_{i \text{CO}_2}) ; \sum (\text{Vol. Fuel}_i * \text{EF Fuel}_{i \text{CH}_4}) ; \sum (\text{Vol. Fuel}_i * \text{EF Fuel}_{i \text{N}_2\text{O}})$					
	Emissions <sub>Injection Unit Operation</sub>	kg of CO <sub>2</sub> ; CH <sub>4</sub> ; N <sub>2</sub> O	N/A	N/A	N/A	Quantity being calculated in aggregate form as fuel use on site is likely aggregated for each of these SS's.
	Volume of Each Type of Fuel Used / Vol. Fuel <sub>i</sub>	L / m <sup>3</sup> / other	Measured	Direct metering or reconciliation of volume in storage (including volumes received).	Continuous metering or monthly reconciliation	Both methods are standard practice. Frequency of metering is highest level possible. Frequency of reconciliation provides for reasonable diligence.
	CO <sub>2</sub> Emissions Factor for Each Type of Fuel / EF Fuel <sub>i CO2</sub>	kg CO <sub>2</sub> per L / m <sup>3</sup> / other	Estimate	From Environment Canada reference documents. (Appendix A)	Annual	Reference values adjusted annually as part of Environment Canada's emissions inventory.
	CH <sub>4</sub> Emissions Factor for Each Type of Fuel /	kg CH <sub>4</sub> per L / m <sup>3</sup> / other	Estimate	From Environment Canada reference documents.	Annual	Reference values adjusted annually as part of Environment Canada's emissions inventory.

1.0 Project/Baseline SS	2. Parameter / Variable	3. Unit	4. Measured / Estimated	5. Method	6. Frequency	7. Justify measurement or estimation and frequency
	EF Fuel <sub>iCH4</sub>			(Appendix A)		
	N <sub>2</sub> O Emissions Factor for Each Type of Fuel / EF Fuel <sub>iN2O</sub>	kg N <sub>2</sub> O per L / m <sup>3</sup> / other	Estimate	From Environment Canada reference documents (Appendix A).	Annual	Reference values adjusted annually as part of Environment Canada's emissions inventory.
<b>Emissions<sub>Recycled Gas</sub> = Σ (Vol.<sub>Recycled Gas</sub> * % CO<sub>2</sub> * ρ<sub>CO2</sub>)</b>						
P10 Recycled Gas	Emissions <sub>Recycled Gas</sub>	kg CO <sub>2</sub>	N/A	N/A	N/A	Quantity being calculated.
	Volume of Gas Produced at Wells Within the Same Reservoir / Vol. <sub>Adjacent Gas</sub>	m <sup>3</sup>	Measured	Direct metering of volume of gas produced at wells within the same reservoir over the reporting period converted to STP conditions.	Continuous metering	Direct metering is standard practice. Frequency of metering is highest level possible.
	CO <sub>2</sub> Composition in Adjacent Gas / % CO <sub>2</sub>	%	Measured	Direct Measurement	Monthly sampling	Gas composition should remain relatively stable during steady-state operation. Frequency of reconciliation provides for reasonable diligence.
	Density of CO <sub>2</sub> / ρ <sub>CO2</sub>	kg/m <sup>3</sup>	Constant	1.98 kg/m <sup>3</sup> at STP	N/A	Accepted value
<b>Baseline SS's</b>						
B9 Fuel Extraction / Processing	Emissions <sub>Fuel Extraction / Processing</sub> = Σ (Vol. <sub>Fuel I</sub> * EF Fuel <sub>iCO2</sub> ) ; Σ (Vol. <sub>Fuel I</sub> * EF Fuel <sub>iCH4</sub> ) ; Σ (Vol. <sub>Fuel I</sub> * EF Fuel <sub>iN2O</sub> ) ;					
	Emissions <sub>Fuel Extraction / Processing</sub>	kg of CO <sub>2</sub> ; CH <sub>4</sub> ; N <sub>2</sub> O	N/A	N/A	N/A	Quantity being calculated in aggregate form as fuel use on site is likely aggregated for each of these SS's.
	Volume of Each Type of Fuel Combusted for B5 / Vol. <sub>Fuel i</sub>	L / m <sup>3</sup> / other	Measured	Direct metering or reconciliation of volume in storage (including volumes received).	Continuous metering or monthly reconciliation	Both methods are standard practice. Frequency of metering is highest level possible. Frequency of reconciliation provides for reasonable diligence.
	CO <sub>2</sub> Emissions	kg CO <sub>2</sub> per L /	Estimate	From Environment	Annual	Reference values adjusted annually as

1.0 Project/Baseline SS	2. Parameter / Variable	3. Unit	4. Measured / Estimated	5. Method	6. Frequency	7. Justify measurement or estimation and frequency
	Factor for Fuel Including Production and Processing / $EF_{Fuel_i CO_2}$	$m^3$ / other		Canada reference documents. (Appendix A)		part of Environment Canada's emissions inventory.
	CH <sub>4</sub> Emissions Factor for Fuel Including Production and Processing / $EF_{Fuel_i CH_4}$	kg CH <sub>4</sub> per L / $m^3$ / other	Estimate	From Environment Canada reference documents. (Appendix A)	Annual	Reference values adjusted annually as part of Environment Canada's emissions inventory.
	N <sub>2</sub> O Emissions Factor for Fuel Including Production and Processing / $EF_{Fuel_i N_2O}$	kg N <sub>2</sub> O per L / $m^3$ / other	Estimate	From Environment Canada reference documents (Appendix A).	Annual	Reference values adjusted annually as part of Environment Canada's emissions inventory.
B5a Liquid Redox Process	Emissions <sub>Liquid Redox Process</sub> = $\Sigma (Vol. Fuel_i * EF_{Fuel_i CO_2}) ; \Sigma (Vol. Fuel_i * EF_{Fuel_i CH_4}) ; \Sigma (Vol. Fuel_i * EF_{Fuel_i N_2O})$					
	Emissions <sub>Liquid Redox Process</sub>	kg of CO <sub>2</sub> ; CH <sub>4</sub> ; N <sub>2</sub> O	N/A	N/A	N/A	Quantity being calculated in aggregate form as fuel use on site is likely aggregated for each of these SS's.
	Volume of Each Type of Fuel Used / Vol. Fuel <sub>i</sub>	L / $m^3$ / other	Estimate	Project Specific Design	Project Development	Engineering report will provide the volume of fuel required for an appropriately sized Liquid Redox Process. Represents most reasonable means of estimation.
	CO <sub>2</sub> Emissions Factor for Each Type of Fuel / $EF_{Fuel_i CO_2}$	kg CO <sub>2</sub> per L / $m^3$ / other	Estimate	From Environment Canada reference documents. (Appendix A)	Annual	Reference values adjusted annually as part of Environment Canada's emissions inventory.
	CH <sub>4</sub> Emissions Factor for Each Type of Fuel /	kg CH <sub>4</sub> per L / $m^3$ / other	Estimate	From Environment Canada reference documents.	Annual	Reference values adjusted annually as part of Environment Canada's emissions inventory.

1.0 Project/Baseline SS	2. Parameter / Variable	3. Unit	4. Measured / Estimated	5. Method	6. Frequency	7. Justify measurement or estimation and frequency
	EF Fuel <sub>i</sub> CH <sub>4</sub>			(Appendix A)		
	N <sub>2</sub> O Emissions Factor for Each Type of Fuel / EF Fuel <sub>i</sub> N <sub>2</sub> O	kg N <sub>2</sub> O per L / m <sup>3</sup> / other	Estimate	From Environment Canada reference documents. (Appendix A)	Annual	Reference values adjusted annually as part of Environment Canada's emissions inventory.
B5b Multi-Stage Claus Unit	$\text{Emissions}_{\text{Multi-Stage Claus Unit}} = \sum (\text{Vol. Fuel}_i - ((E_{\text{Claus}} * \eta_{\text{Heat}}) / (\eta_{\text{Energy}} * \omega_{\text{Fuel}_i}))) * \text{EF Fuel}_{i\text{CO}_2} ;$ $\sum (\text{Vol. Fuel}_i - ((E_{\text{Claus}} * \eta_{\text{Heat}}) / (\eta_{\text{Energy}} * \omega_{\text{Fuel}_i}))) * \text{EF Fuel}_{i\text{CH}_4} ; \sum (\text{Vol. Fuel}_i - ((E_{\text{Claus}} * \eta_{\text{Heat}}) / (\eta_{\text{Energy}} * \omega_{\text{Fuel}_i}))) * \text{EF Fuel}_{i\text{N}_2\text{O}}$					
	Emissions <sub>Multi-Stage Claus Unit</sub>	kg of CO <sub>2</sub> ; CH <sub>4</sub> ; N <sub>2</sub> O	N/A	N/A	N/A	Quantity being calculated in aggregate form as fuel use on site is likely aggregated for each of these SS's.
	Volume of Each Type of Fuel Used / Vol. Fuel <sub>i</sub>	L / m <sup>3</sup> / other	Estimate	Project Engineering Design	Project Definition	Engineering report will specify the volume of fuel gas required for an appropriately sized Multi-Stage Claus Unit. Represents most reasonable means of estimation.
	Process Energy Recovered / E <sub>Claus</sub>	GJ	Estimate	Project Engineering Design	Project Definition	Engineering report will specify the exothermic energy recovered by an appropriately sized Multi-Stage Claus Unit. Represents most reasonable means of estimation.
	Heat Transfer Efficiency / $\eta_{\text{Heat}}$	-	Estimate	Project Engineering Design	Project Definition	Engineering report will specify the heat design heat transfer efficiency from an appropriately sized Multi-Stage Claus Unit to another process with heat requirements. Represents most reasonable means of estimation.
	Fuel Energy Efficiency / $\eta_{\text{Energy}}$	-	Estimate	Project Engineering Design	Project Definition	Engineering report will specify the fuel energy efficiency of the secondary process. Represents most reasonable means of estimation.
	Realized Energy Density from	GJ / m <sup>3</sup>	Estimate	Project Engineering	Project Definition	Engineering report will specify the energy density of each type of fuel being

1.0 Project/Baseline SS	2. Parameter / Variable	3. Unit	4. Measured / Estimated	5. Method	6. Frequency	7. Justify measurement or estimation and frequency
	Each Type of Fuel / $\omega_{Fuel\ i}$			Design		offset in other processes. Represents most reasonable means of estimation.
	CO <sub>2</sub> Emissions Factor for Each Type of Fuel / EF Fuel <sub>iCO<sub>2</sub></sub>	kg CO <sub>2</sub> per L / m <sup>3</sup> / other	Estimate	From Environment Canada reference documents. (Appendix A)	Annual	Reference values adjusted annually as part of Environment Canada's emissions inventory.
	CH <sub>4</sub> Emissions Factor for Each Type of Fuel / EF Fuel <sub>iCH<sub>4</sub></sub>	kg CH <sub>4</sub> per L / m <sup>3</sup> / other	Estimate	From Environment Canada reference documents. (Appendix A)	Annual	Reference values adjusted annually as part of Environment Canada's emissions inventory.
	N <sub>2</sub> O Emissions Factor for Each Type of Fuel / EF Fuel <sub>iN<sub>2</sub>O</sub>	kg N <sub>2</sub> O per L / m <sup>3</sup> / other	Estimate	From Environment Canada reference documents. (Appendix A)	Annual	Reference values adjusted annually as part of Environment Canada's emissions inventory.
B6 Incineration	Emissions <sub>Incineration</sub> = (Vol. Gas Flared * % CO <sub>2</sub> * $\rho_{CO_2}$ ) ; (((Vol. Gas Flared) * (HV <sub>combined</sub> - HV <sub>tail</sub> )/(HV <sub>fuel</sub> - HV <sub>combined</sub> )) * EF Fuel <sub>iCO<sub>2</sub></sub> ) ; (((Vol. Gas Flared) * (HV <sub>combined</sub> - HV <sub>tail</sub> )/(HV <sub>fuel</sub> - HV <sub>combined</sub> )) * EF Fuel <sub>iCH<sub>4</sub></sub> ) ; (((Vol. Gas Flared) * (HV <sub>combined</sub> - HV <sub>tail</sub> )/(HV <sub>fuel</sub> - HV <sub>combined</sub> )) * EF Fuel <sub>iN<sub>2</sub>O</sub> ) ;					
	Emissions <sub>Incineration</sub>	kg CO <sub>2</sub> ; CH <sub>4</sub> ; N <sub>2</sub> O	N/A	N/A	N/A	Quantity being calculated in aggregate form as fuel use on site is likely aggregated for each of these SS's.
	Volume of Gas Flared / Vol. Gas Flared	m <sup>3</sup>	Measured	Direct metering of volume of gas entering process.	Continuous metering.	Direct metering is standard practice. Frequency of metering is the highest level possible.
	CO <sub>2</sub> Composition in Gas / % CO <sub>2</sub>	%	Measured	Direct measurement	Weekly sampling averaged monthly on a volumetric basis	Gas composition should remain relatively stable during steady-state operation. Frequency of reconciliation provides for reasonable diligence.
	Density of CO <sub>2</sub> / $\rho_{CO_2}$	kg / m <sup>3</sup>	Constant	1.98 kg/m <sup>3</sup> at STP	N/A	Accepted value
	Heat Value of	MJ / m <sup>3</sup>	Estimated	Project	Project	Gas composition should remain

1.0 Project/Baseline SS	2. Parameter / Variable	3. Unit	4. Measured / Estimated	5. Method	6. Frequency	7. Justify measurement or estimation and frequency
	Tail Gas / HV <sub>tail</sub>			Engineering Design	Definition	relatively stable during steady-state operation. Engineering report will specify the expected tail gas heat value for an appropriately sized multi-stage Claus unit.
	Heat Value of Fuel Gas used to Supplement Flare / HV <sub>fuel</sub>	MJ / m <sup>3</sup>	Measured	Direct Measurement	Monthly sampling	Gas composition should remain relatively stable during steady-state operation. Frequency of reconciliation provides for reasonable diligence.
	Heat Value of Combined Tail Gas and Fuel Gas / HV <sub>combined</sub>	MJ / m <sup>3</sup>	Estimated	20 MJ / m <sup>3</sup>	N/A	Minimum value required by EUB Directive 060: Upstream Petroleum Industry Flaring, Incinerating, and Venting (November 2006).
	CO <sub>2</sub> Emissions Factor for Each Type of Fuel <sub>i</sub>	kg CO <sub>2</sub> per L / m <sup>3</sup> / other	Estimate	From Environment Canada reference documents. (Appendix A)	Annual	Reference values adjusted annually as part of Environment Canada's emissions inventory.
	CH <sub>4</sub> Emissions Factor for Each Type of Fuel <sub>i</sub>	kg CH <sub>4</sub> per L / m <sup>3</sup> / other	Estimate	From Environment Canada reference documents. (Appendix A)	Annual	Reference values adjusted annually as part of Environment Canada's emissions inventory.
	N <sub>2</sub> O Emissions Factor for Each Type of Fuel <sub>i</sub>	kg N <sub>2</sub> O per L / m <sup>3</sup> / other	Estimate	From Environment Canada reference documents. (Appendix A)	Annual	Reference values adjusted annually as part of Environment Canada's emissions inventory.

## 2.5.2 Contingent Data Approaches

Contingent means for calculating or estimating the required data for the equations outlined in section 2.5.1 are summarized in **TABLE 2.5**, below.

## 2.6 Management of Data Quality

In general, data quality management must include sufficient data capture such that the mass and energy balances may be easily performed with the need for minimal assumptions and use of contingency procedures. The data should be of sufficient quality to fulfill the quantification requirements and be substantiated by company records for the purpose of verification.

The project proponent shall establish and apply quality management procedures to manage data and information. Written procedures should be established for each measurement task outlining responsibility, timing and record location requirements. The greater the rigour of the management system for the data, the more easily an audit will be to conduct for the project.

### 2.6.1 Record Keeping

Record keeping practises should include:

- a. Electronic recording of values of logged primary parameters measurement interval;
- b. Printing of monthly back-up hard copies of all logged data;
- c. Written logs of operations and maintenance of the project system notation of all shut-downs, start-ups and process adjustments;
- d. Retention of copies of logs and all logged data for a period of 7 years;
- e. Keeping all records available for review by a verification body.

### 2.6.1 Quality Assurance/Quality Control (QA/QC)

QA/QC can also be applied to add confidence that all measurements and calculations have been made correctly. These include, but are not limited to:

- a. Protecting monitoring equipment (sealed meters and data loggers);
- b. Protecting records of monitored data (hard copy and electronic storage);
- c. Checking data integrity on a regular and periodic basis (manual assessment, comparing redundant metered data, and detection of outstanding data/records);
- d. Comparing current estimates with previous estimates as a 'reality check';
- e. Provide sufficient training to operators to perform maintenance and calibration of monitoring devices;
- f. Establish minimum experience and requirements for operators in charge of project and monitoring; and
- g. Performing recalculations to make sure no mathematical errors have been made.

Table 2.5: Contingent Data Collection Procedures

1.0 Project/Baseline SS	2. Parameter / Variable	3. Unit	4. Measured / Estimated	5. Method	6. Frequency	7. Justify measurement or estimation and frequency
<b>Project SS's</b>						
P12 Fuel Extraction / Processing	Volume of Each Type of Fuel Combusted for P5 to P8 / Vol. Fuel <sub>i</sub>	L / m <sup>3</sup> / other	Estimate	Reconciliation of volume of fuel purchased within a given time period.	Monthly	Provides reasonable estimate of the parameter, when more accurate and precise method cannot be used.
P6 Acid Gas Dehydration and Compression	Volume of Each Type of Fuel Used / Vol. Fuel <sub>i</sub>	L / m <sup>3</sup> / other	Estimate	Reconciliation of volume of fuel purchased within a given time period.	Monthly	Provides reasonable estimate of the parameter, when more accurate and precise method cannot be used.
	CO <sub>2</sub> Emissions Factor for Each Type of Fuel <sub>i</sub>	kg CO <sub>2</sub> per L / m <sup>3</sup> / other	Measured	Direct Measurement	Daily	Gas composition should remain relatively stable during steady-state operation. Frequency of reconciliation provides for reasonable diligence.
	CH <sub>4</sub> Emissions Factor for Each Type of Fuel / EF Fuel <sub>i</sub> CH <sub>4</sub>	kg CO <sub>2</sub> per L / m <sup>3</sup> / other	Measured	Direct Measurement	Daily	Gas composition should remain relatively stable during steady-state operation. Frequency of reconciliation provides for reasonable diligence.
	N <sub>2</sub> O Emissions Factor for Each Type of Fuel / EF Fuel <sub>i</sub> N <sub>2</sub> O	kg CO <sub>2</sub> per L / m <sup>3</sup> / other	Measured	Direct Measurement	Daily	Gas composition should remain relatively stable during steady-state operation. Frequency of reconciliation provides for reasonable diligence.
P8 Upset Flaring	Volume of Acid Gas Flared / Vol. AG Flared	m <sup>3</sup>	Estimated	Reconciliation of volume of fuel consumed within given time period based on equipment efficiency specifications and average flow rates.	Monthly	Provides reasonable estimate of the parameter, when more accurate and precise method cannot be used.
	Carbon Dioxide Composition in AG / % CO <sub>2</sub>	%	Estimated	Interpolation of previous and following	Daily	Acid gas composition should remain relatively stable during steady-state operation. Interpolating gas composition

				measurements taken.		provides a reasonable estimate when the more accurate and precise method cannot be used.
	Volume of Each Type of Fuel used to Supplement Flare / Vol Fuel <sub>i</sub>	L / m <sup>3</sup> / other	Estimated	Reconciliation of volume of fuel purchased within a given time period.	Monthly	Provides reasonable estimate of the parameter, when more accurate and precise method cannot be used.
	CO <sub>2</sub> Emissions Factor for Each Type of Fuel <sub>i</sub>	kg CO <sub>2</sub> per L / m <sup>3</sup> / other	Measured	Direct Measurement	Daily	Gas composition should remain relatively stable during steady-state operation. Frequency of reconciliation provides for reasonable diligence.
	CH <sub>4</sub> Emissions Factor for Each Type of Fuel / EF Fuel <sub>i</sub> CH <sub>4</sub>	kg CO <sub>2</sub> per L / m <sup>3</sup> / other	Measured	Direct Measurement	Daily	Gas composition should remain relatively stable during steady-state operation. Frequency of reconciliation provides for reasonable diligence.
	N <sub>2</sub> O Emissions Factor for Each Type of Fuel / EF Fuel <sub>i</sub> N <sub>2</sub> O	kg CO <sub>2</sub> per L / m <sup>3</sup> / other	Measured	Direct Measurement	Daily	Gas composition should remain relatively stable during steady-state operation. Frequency of reconciliation provides for reasonable diligence.
P9 Injection Unit Operation	Volume of Each Type of Fuel Used / Vol Fuel <sub>i</sub>	L / m <sup>3</sup> / other	Estimated	Reconciliation of volume of fuel purchased within a given time period.	Monthly	Provides reasonable estimate of the parameter, when more accurate and precise method cannot be used.
	CO <sub>2</sub> Emissions Factor for Each Type of Fuel <sub>i</sub>	kg CO <sub>2</sub> per L / m <sup>3</sup> / other	Measured	Direct Measurement	Daily	Gas composition should remain relatively stable during steady-state operation. Frequency of reconciliation provides for reasonable diligence.
	CH <sub>4</sub> Emissions Factor for Each Type of Fuel / EF Fuel <sub>i</sub> CH <sub>4</sub>	kg CO <sub>2</sub> per L / m <sup>3</sup> / other	Measured	Direct Measurement	Daily	Gas composition should remain relatively stable during steady-state operation. Frequency of reconciliation provides for reasonable diligence.
	N <sub>2</sub> O Emissions Factor for Each Type of Fuel / EF Fuel <sub>i</sub> N <sub>2</sub> O	kg CO <sub>2</sub> per L / m <sup>3</sup> / other	Measured	Direct Measurement	Daily	Gas composition should remain relatively stable during steady-state operation. Frequency of reconciliation provides for reasonable diligence.
P10 Recycled Gas	CO <sub>2</sub> Composition in	%	Estimated	Interpolation of previous and	Monthly	Raw gas composition should remain relatively stable during steady-state

	Adjacent Gas / % CO <sub>2</sub>			following measurements taken.		operation. Interpolating gas composition provides a reasonable estimate when the more accurate and precise method cannot be used.
<b>Baseline SS's</b>						
B9 Fuel Extraction / Processing	Volume of Each Type of Fuel Combusted for B5 / Vol. Fuel <sub>i</sub>	L / m <sup>3</sup> / other	Estimate	Reconciliation of volume of fuel purchased within a given time period.	Monthly	Provides reasonable estimate of the parameter, when more accurate and precise method cannot be used.
B6 Incineration	Volume of Gas Flared / Vol. Gas Flared	m <sup>3</sup>	Estimated	Reconciliation of volume of fuel consumed within given time period based on equipment efficiency specifications and average flow rates.	Monthly	Provides reasonable estimate of the parameter, when more accurate and precise method cannot be used.
	CO <sub>2</sub> Composition in Gas / % CO <sub>2</sub>	%	Estimated	Interpolation of previous and following measurements taken.	Daily	Acid gas composition should remain relatively stable during steady-state operation. Interpolating gas composition provides a reasonable estimate when the more accurate and precise method cannot be used.
	Heat Value of Fuel Gas used to Supplement Flare / HV <sub>fuel</sub>	MJ / m <sup>3</sup>	Measured	From Environment Canada reference documents. (Appendix A)o	Annual	Reference values adjusted annually as part of Environment Canada's emissions inventory.
	CO <sub>2</sub> Emissions Factor for Each Type of Fuel <sub>i</sub>	kg CO <sub>2</sub> per L / m <sup>3</sup> / other	Measured	Direct Measurement	Daily	Gas composition should remain relatively stable during steady-state operation. Frequency of reconciliation provides for reasonable diligence.
	CH <sub>4</sub> Emissions Factor for Each Type of Fuel / EF Fuel <sub>i</sub> CH <sub>4</sub>	kg CO <sub>2</sub> per L / m <sup>3</sup> / other	Measured	Direct Measurement	Daily	Gas composition should remain relatively stable during steady-state operation. Frequency of reconciliation provides for reasonable diligence.
	N <sub>2</sub> O Emissions Factor for Each	kg CO <sub>2</sub> per L / m <sup>3</sup> / other	Measured	Direct Measurement	Daily	Gas composition should remain relatively stable during steady-state

---

	Type of Fuel / EF Fuel <sub>i N2O</sub>					operation. Frequency of reconciliation provides for reasonable diligence.
--	--	--	--	--	--	--

DRAFT

**APPENDIX A:**  
**Relevant Emission Factors<sup>1</sup>**

DRAFT

---

<sup>1</sup> Source: Environment Canada (*subject to updates*)

**Table A1: Emission Intensity of Fuel Extraction and Production (Diesel, Natural Gas, and Gasoline)**

<b>Diesel</b>		
<b>Production</b>		
Emissions Factor (CO <sub>2</sub> )	0.138	kg CO <sub>2</sub> per Litre
Emissions Factor (CH <sub>4</sub> )	0.0109	kg CH <sub>4</sub> per Litre
Emissions Factor (N <sub>2</sub> O)	0.000004	kg N <sub>2</sub> O per Litre
<b>Natural Gas</b>		
<b>Extraction</b>		
Emissions Factor (CO <sub>2</sub> )	0.043	kg CO <sub>2</sub> per m <sup>3</sup>
Emissions Factor (CH <sub>4</sub> )	0.0023	kg CH <sub>4</sub> per m <sup>3</sup>
Emissions Factor (N <sub>2</sub> O)	0.000004	kg N <sub>2</sub> O per m <sup>3</sup>
<b>Processing</b>		
Emissions Factor (CO <sub>2</sub> )	0.090	kg CO <sub>2</sub> per m <sup>3</sup>
Emissions Factor (CH <sub>4</sub> )	0.0003	kg CH <sub>4</sub> per m <sup>3</sup>
Emissions Factor (N <sub>2</sub> O)	0.000003	kg N <sub>2</sub> O per m <sup>3</sup>
<b>Gasoline</b>		
<b>Production</b>		
Emissions Factor (CO <sub>2</sub> )	0.138	kg CO <sub>2</sub> per Litre
Emissions Factor (CH <sub>4</sub> )	0.0109	kg CH <sub>4</sub> per Litre
Emissions Factor (N <sub>2</sub> O)	0.000004	kg N <sub>2</sub> O per Litre

**Table A2: Emission Factors for Natural Gas and NGL's**

<b>Source</b>	<b>Emission Factors</b>		
	<b>CO<sub>2</sub></b>	<b>CH<sub>4</sub></b>	<b>N<sub>2</sub>O</b>
	<b>g/m<sup>3</sup></b>	<b>g/m<sup>3</sup></b>	<b>g/m<sup>3</sup></b>
<b>Natural Gas</b>			
Electric Utilities	1891	0.49	0.049
Industrial	1891	0.037	0.033
Producer Consumption	2389	6.5	0.06
Pipelines	1891	1.9	0.05

Cement	1891	0.037	0.034
Manufacturing Industries	1891	0.037	0.033
Residential, Construction, Commercial/Institutional, Agriculture	1891	0.037	0.035
	<b>g/L</b>	<b>g/L</b>	<b>g/L</b>
<b>Propane</b>			
Residential	1510	0.027	0.108
All Other Uses	1510	0.024	0.108
<b>Ethane</b>	976	N/A	N/A
<b>Butane</b>	1730	0.024	0.108

**Table A3: Emission Factors for Refined Petroleum Products**

Source	Emission Factors (g/L)		
	CO <sub>2</sub>	CH <sub>4</sub>	N <sub>2</sub> O
<b>Light Fuel Oil</b>			
Electric Utilities	2830	0.18	0.031
Industrial	2830	0.006	0.031
Producer Consumption	2830	0.006	0.031
Residential	2830	0.026	0.006
Forestry, Construction, Public Administration, and Commercial/Institutional	2830	0.026	0.031
<b>Heavy Fuel Oil</b>			
Electric Utilities	3080	0.034	0.064
Industrial	3080	0.12	0.064
Producer Consumption	3080	0.12	0.064

Residential, Forestry, Construction, Public Administration, and Commercial/Institutional	3080	0.057	0.064
<b>Kerosene</b>			
Electric Utilities	2550	0.006	0.031
Industrial	2550	0.006	0.031
Producer Consumption	2550	0.006	0.031
Residential	2550	0.026	0.006
Forestry, Construction, Public Administration, and Commercial/ Institutional	2550	0.026	0.031
<b>Diesel</b>	2730	0.133	0.4

DRAFT